

# Refrigerant R410A Cassette Type SPLIT TYPE AIR CONDITIONER INSTALLATION INSTRUCTION SHEET

(PART NO. 9365388068-04)

For authorized service personnel only.

|                |   |
|----------------|---|
| <b>WARNING</b> | This mark indicates procedures which, if improperly performed, might lead to the death or serious injury of the user.                     |
| <b>CAUTION</b> | This mark indicates procedures which, if improperly performed, might possibly result in personal harm to the user, or damage to property. |

## This air conditioner uses new refrigerant HFC (R410A).

The basic installation work procedures are the same as conventional refrigerant (R22) models. However, pay careful attention to the following points:

- Since the working pressure is 1.6 times higher than that of conventional refrigerant (R22) models, some of the piping and installation and service tools are special. (See the table below.) Especially, when replacing a conventional refrigerant (R22) model with a new refrigerant R410A model, always replace the conventional piping and flare nuts with the R410A piping and flare nuts.
- Models that use refrigerant R410A have a different charging port thread diameter to prevent erroneous charging with conventional refrigerant (R22) and for safety. Therefore, check beforehand. [The charging port thread diameter for R410A is 1/2 UNF 20 threads per inch.]
- Be more careful that foreign matter (oil, water, etc.) does not enter the piping than with refrigerant (R22) models. Also, when storing the piping, securely seal the openings by pinching, taping, etc.
- When charging the refrigerant, take into account the slight change in the composition of the gas and liquid phases, and always charge from the liquid phase side whose composition is stable.

### Special tools for R410A

| Tool name            | Contents of change  |
|----------------------|---|
| Gauge manifold       | Pressure is high and cannot be measured with a conventional gauge. To prevent erroneous mixing of other refrigerants, the diameter of each port has been changed. It is recommended the gauge with seal: -0.1 to 5.3 MPa (-76 cmHg to 53 kgf/cm <sup>2</sup> ) for high pressure. -0.1 to 3.8 MPa (-76 cmHg to 38 kgf/cm <sup>2</sup> ) for low pressure. |
| Charge hose          | To increase pressure resistance, the hose material and base size were changed.  |
| Vacuum pump          | A conventional vacuum pump can be used by installing a vacuum pump adapter.   |
| Gas leakage detector | Special gas leakage detector for HFC refrigerant R410A.   |

### Copper pipes

It is necessary to use seamless copper pipes and it is desirable that the amount of residual oil is less than 40 mg/10 m. Do not use copper pipes having a collapsed, deformed or discolored portion (especially on the interior surface). Otherwise, the expansion valve or capillary tube may become blocked with contaminants. As an air conditioner using R410A incurs pressure higher than when using conventional refrigerant, it is necessary to choose adequate materials. Thicknesses of copper pipes used with R410A are as shown in the table. Never use copper pipes thinner than that in the table even when it is available on the market.

### Thicknesses of Annealed Copper Pipes (R410A)

| Pipe outside diameter | Thickness |
|-----------------------|-----------|
| 6.35 mm (1/4 in.)     | 0.80 mm   |
| 9.52 mm (3/8 in.)     | 0.80 mm   |
| 12.70 mm (1/2 in.)    | 0.80 mm   |
| 15.88 mm (5/8 in.)    | 1.00 mm   |
| 19.05 mm (3/4 in.)    | 1.20 mm   |

## STANDARD PARTS

The following installation parts are furnished. Use them as required.

### INDOOR UNIT ACCESSORIES

| Name and Shape               | Q'ty      | Application                            |
|------------------------------|-----------|--|
| Coupler heat insulation      | 2         | For indoor side pipe joint             |
| Special nut A (large flange) | 4         | For installing indoor unit             |
| Special nut B (small flange) | 4         | For installing indoor unit             |
| Template                     | 1         | For ceiling hole cutting               |
| Blower cover insulation      | 2         | For discharged air                     |
| Hook wire                    | 2         | For installing intake grille           |
| Blinder                      | 1 (small) | For fixing the remote controller cable |
| Remote controller            | 1         |  |
| Tagging screw (flush heads)  | 2         | For installing the remote controller   |
| Remote controller cable      | 1         | For connecting the remote controller   |

### OUTDOOR UNIT ACCESSORIES

|            |   |   |
|------------|---|---|
| Drain pipe | 1 | For outdoor unit drain piping work (May not be supplied, depending on the model.) |
| Drain cap  | 1 |   |

### OPTIONS

The following options are available.

- ADDITIONAL GRILLE ASSY: UTG-AGEA-W (P/N 9002230002)

## INSTALLATION PROCEDURE

Install the air conditioner as follows:

### 1 INDOOR UNIT INSTALLATION

#### WARNING

- Install the air conditioner in a location which can withstand a load do at least five times the weight of the main unit and which will not amplify sound or vibration. If the installation location is not strong enough, the indoor unit may fall and cause injuries.
- If the job is done with the panel frame only, there is a risk that the unit will come loose. Please take care.

#### REMOVING THE INTAKE GRILLE

- Push the intake grille pushbuttons (two places).
- Open the intake grille.

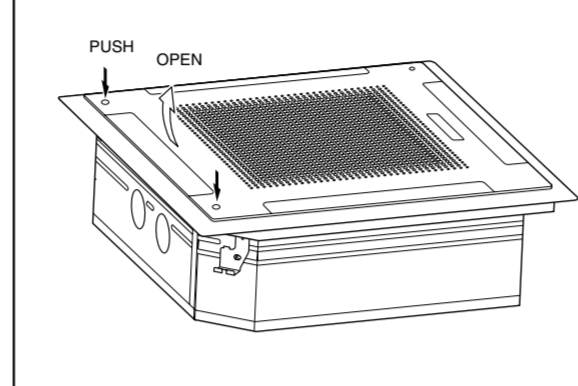

- Remove the grille hinge wire.

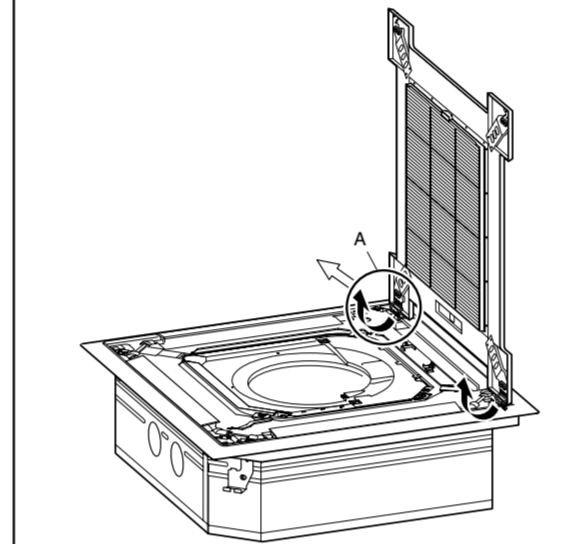

- Pull up while pressing the B section.

#### Part A detail view

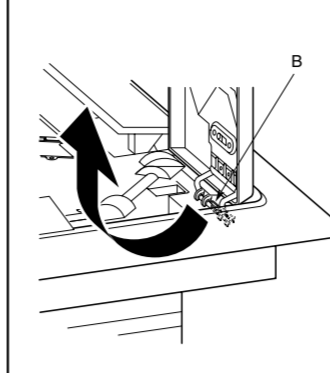

#### Part A section view

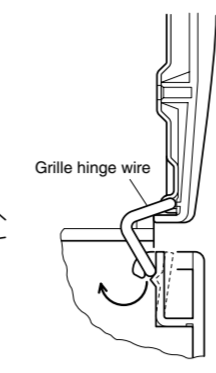

- Remove the intake grille.

#### REMOVING THE PANEL FRAME

- Pull up the corner sections (A) of the panel frame as shown in the figure (4 locations).

#### Part A detail view

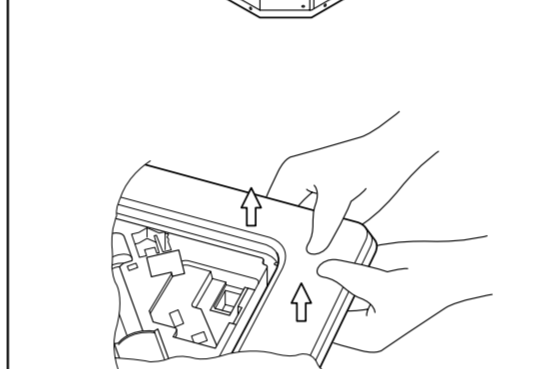
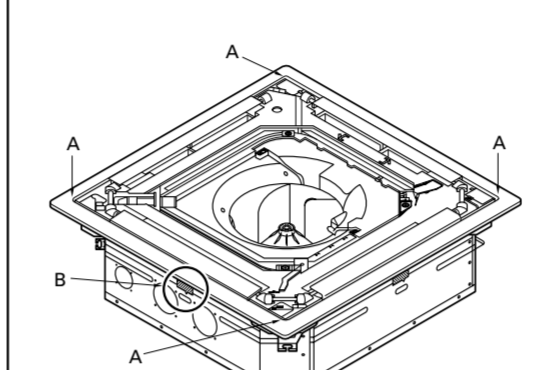

#### Part B detail view

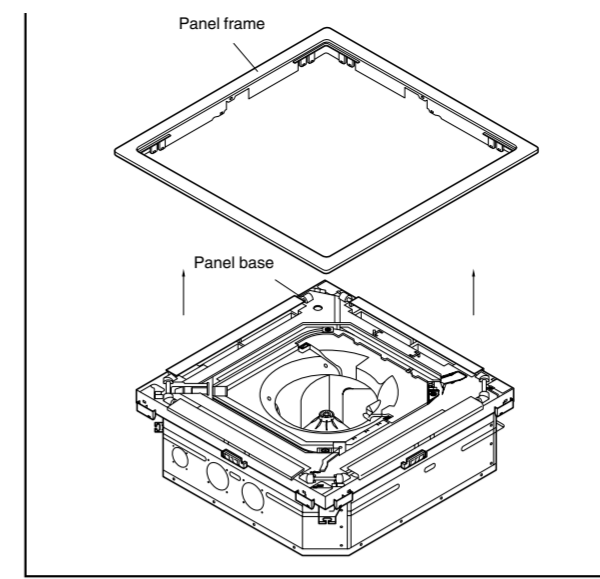
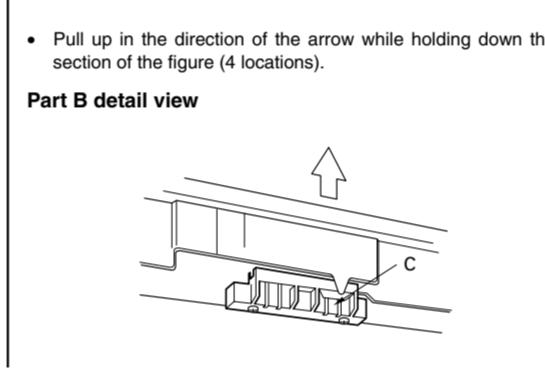

#### CAUTION

Always remove the panel frame after removing the intake grille.

### 1. POSITION THE CEILING HOLE AND HANGING BOLTS

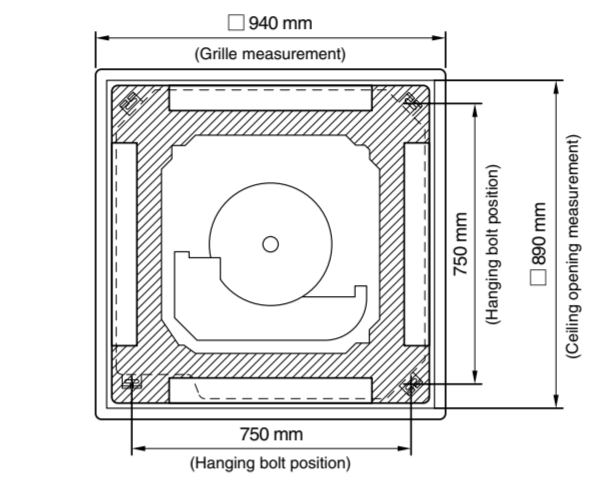

### 2. HANGING PREPARATIONS

- Firmly fasten the hanging bolts as shown in the figure or by another method.
- Install the hanging bolts at a place where they would be capable of holding a weight of at least 490 N (50 kgf) per bolt.

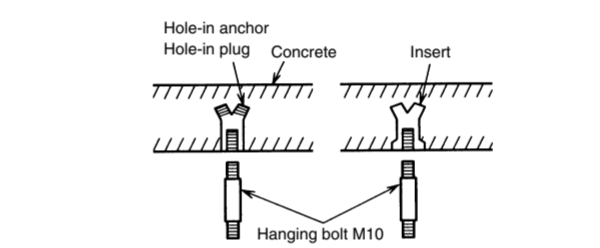

#### (A) Standard setting

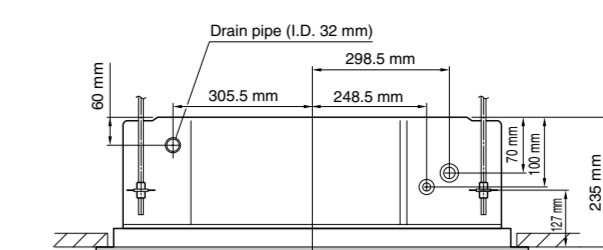

#### (B) Slender setting

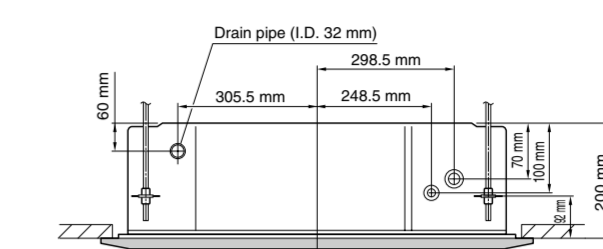

### 3. BODY INSTALLATION

[The ceiling rear height is 235 mm or more.] [Standard setting]

[The ceiling rear height is 200 mm or more.] [Slender setting]

- Install special nut A, then special nut B onto the hanging bolt.
- Raise the body and mount its hooks onto the hanging bolt between the special nuts.
- Turn special nut B to adjust the height of the body.
- Leveling Using a level, or vinyl hose filled with water, fine adjust so that the body is level.

#### WARNING

Perform final tightening by tightening the double nut firmly.

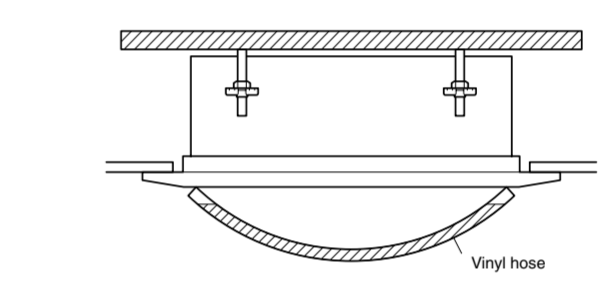
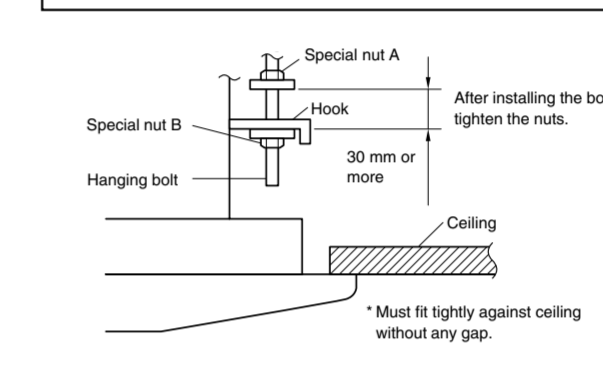

\* Allowable space between the unit and the ceiling 5 mm or less

### INSTALLING THE PANEL FRAME

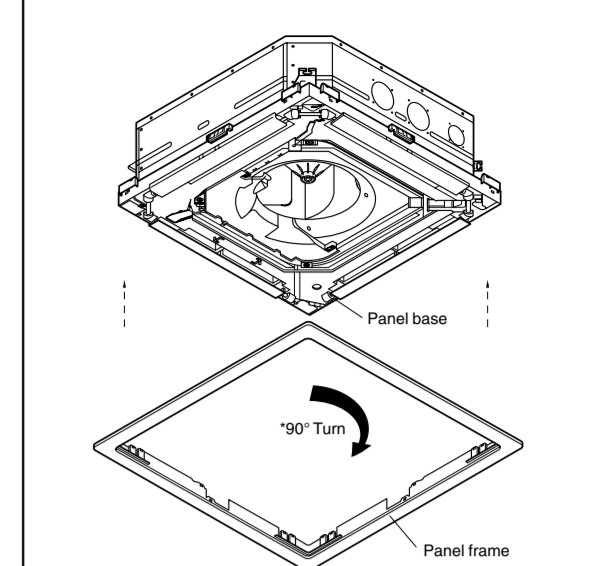

\* With slender setting, turn the panel frame 90° as shown in the diagram above.

#### Grille setting method has been changed at the marked positions on the panel frame and panel base.

(A) Standard setting (B) Slender setting

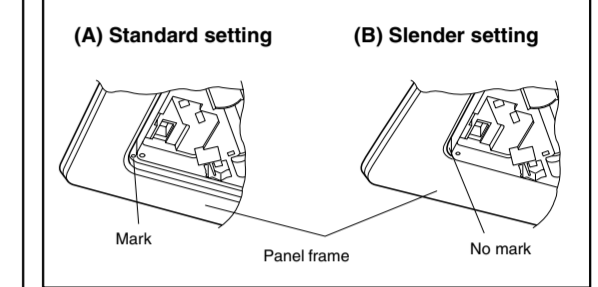

#### (Example)

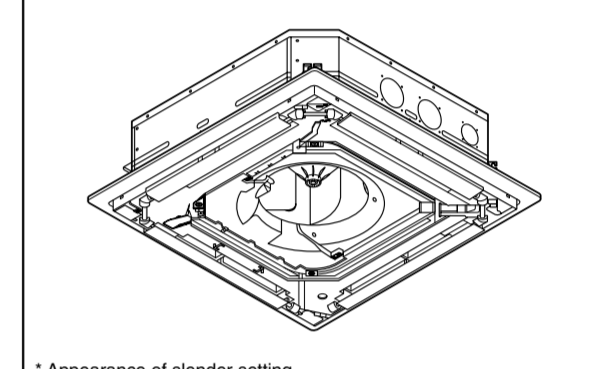

\* Appearance of slender setting

#### WARNING

- For the air conditioner to operate satisfactorily, install it as outlined in this installation instruction sheet.
- Connect the indoor unit and outdoor unit with the air conditioner piping and cables available standards parts. This installation instruction sheet describes the correct connections using the installation set available from our standard parts.
- Installation work must be performed in accordance with national wiring standards by authorized personnel only.
- If refrigerant leaks while work is being carried out, ventilate the area. If the refrigerant comes in contact with a flame, it produces a toxic gas.
- Do not use an extension cable.
- Do not turn on the power until all installation work is complete.

- Be careful not to scratch the air conditioner when handling it.
- After installation, explain correct operation to the customer, using the operating manual.
- Let the customer keep this installation instruction sheet because it is used when the air conditioner is serviced or moved.

### SELECTING THE MOUNTING POSITION

#### WARNING

Install at a place that can withstand the weight of the indoor and outdoor units and install positively so that the units will not topple or fall.

#### CAUTION

- Do not install where there is the danger of combustible gas leakage.
- Do not install near heat sources.
- If children under 10 years old may approach the unit, take preventive measures so that they cannot reach the unit.

Especially, the installation place is very important for the split type air conditioner because it is very difficult to move from place to place after the first installation.

Decide the mounting position together with the customer as follows: The discharge direction can be selected as shown below.

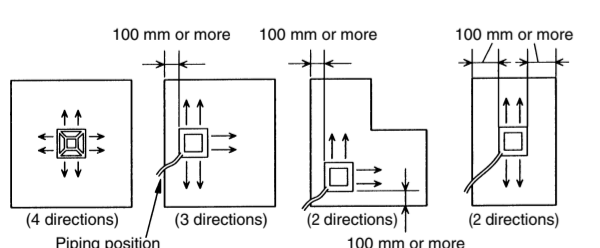

#### CAUTION

Since 2-way outlet as shown below causes performance problems, do not set it.

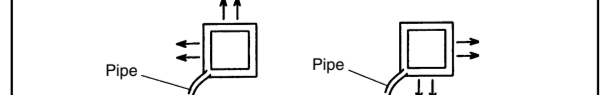

### INDOOR UNIT

- Install the indoor unit on a place having a sufficient strength so that it withstands against the weight of the indoor unit.
- The inlet and outlet ports should not be obstructed; the air should be able to blow all over the room.
- Leave the space required to service the air conditioner.
- The ceiling rear height as shown in the figure.
- A place from where the air can be distributed evenly throughout the room by the unit.
- A place from where drainage can be extracted outdoors easily.
- Install the unit where noise and vibrations are not amplified.

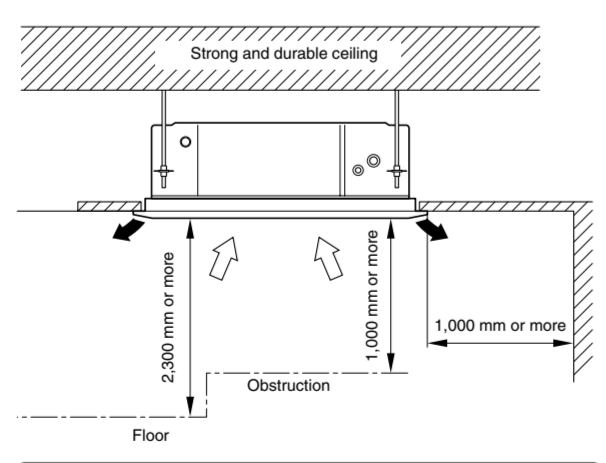

This mechanism enables the cassette body to move 35 mm downward and realizes installation to the space of 215 mm. No special works and option is needed.

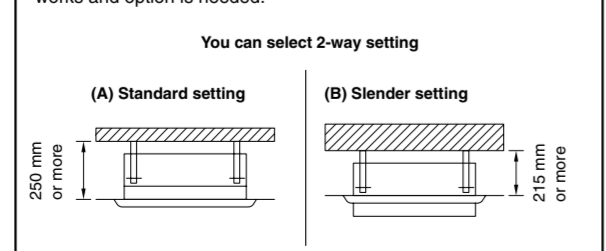

You can select 2-way setting

### OUTDOOR UNIT

#### WARNING

- Install the unit where it will not be tilted by more than 5°.
- When installing the outdoor unit where it may exposed to strong wind, fasten it securely.
- If possible, do not install the unit where it will be exposed to direct sunlight. (If necessary, install a blind that does not interfere with the air flow.)
- Install the outdoor unit in a place where it will be free from being dirty or getting wet by rain as much as possible.
- Install the unit when connection to the indoor unit is easy.
- During heating operation, drain water flows from the outdoor unit. Therefore, install the outdoor unit in a place where the drain water flow will not be obstructed.
- Do not place animals and plants in the path of the warm air.
- Take the air conditioner weight into account and select a place where noise and vibration are small.
- Select a place so that the warm air and noise from the air conditioner do not disturb neighbors.
- Provide the space shown in the figure so that the air flow is not blocked. Also for efficient operation, leave open three of the four directions front, rear, and both sides.
- Do not set the unit directly on the ground because it will cause trouble.
- Set the unit on a strong stand, such as one made of concrete blocks to minimize shock and vibration.

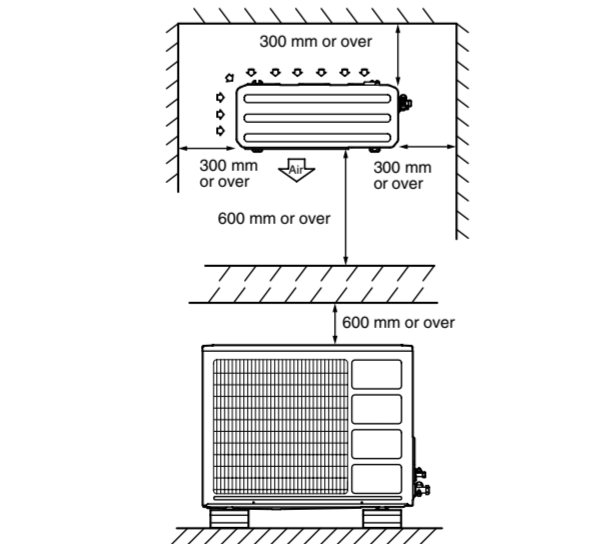

### SAFETY PRECAUTIONS

#### WARNING

- During installation, make sure that the refrigerant pipe is attached firmly before you run the compressor. Do not operate the compressor under the condition of refrigerant piping not attached properly with 2-way or 3-way valve open. This may cause abnormal pressure in the refrigeration cycle that leads to breakage and even injury.
- During the pump-down operation, make sure that the compressor is turned off before you remove the refrigerant piping. Do not remove the connection pipe while the compressor is in operation with 2-way or 3-way valve open. This may cause abnormal pressure in the refrigeration cycle that leads to breakage and even injury.
- When installing and relocating the air conditioner, do not mix gases other than the specified refrigerant (R410A) to enter the refrigerant cycle. If air or other gas enters the refrigerant cycle, the pressure inside the cycle will rise to an abnormally high value and cause breakage, injury, etc.

### CONNECTION PIPE REQUIREMENT

#### CAUTION

The maximum lengths of this product are shown in the following table. If the units are further apart than this, correct operation can not be guaranteed.

| Liquid            | Gas                | Pipe length |      | Maximum height (between indoor and outdoor) |
|-------------------|--------------------|-------------|------|---|
|                   |                    | MAX.        | MIN. |   |
| 9.52 mm (3/8 in.) | 15.88 mm (5/8 in.) | 25 m        | 5 m  | 15 m  |

- Use pipe with water-resistant heat insulation.

#### CAUTION

Install heat insulation around both the gas and liquid pipes. Failure to do so may cause water leaks. Use heat insulation with heat resistance above 120 °C. (Reverse cycle model only) In addition, if the humidity level at the installation location of the refrigerant piping is expected to exceed 70%, install heat insulation around the refrigerant piping. If the expected humidity level is 70-80%, use heat insulation that is 15 mm or thicker and if the expected humidity exceeds 80%, use heat insulation that is 20 mm or thicker. If heat insulation is used that is not as thick as specified, condensation may form on the surface of the insulation. In addition, use heat insulation with heat conductivity of 0.045 W/(m·K) or less (at 20 °C).

### ELECTRICAL REQUIREMENT

- Electric wire size and breaker capacity:

|              | Power supply cable (mm <sup>2</sup> ) |      | Connection cable (mm <sup>2</sup> ) |      | Breaker capacity (A) |
|--------------|---------------------------------------|------|-------------------------------------|------|----------------------|
|              | MAX.                                  | MIN. | MAX.                                | MIN. |                      |
| 3 phase TYPE | 2.5                                   | 1.5  | 2.5                                 | 1.5  | 10                   |
| 1 phase TYPE | 4.0                                   | 3.5  |                                     |      | 30                   |

- Always use H07RN-F or equivalent to the connection cable.
- Install all electrical works in accordance to the standard.
- Install the disconnect device with a contact gap of at least 3 mm in all poles nearby the units. (Both indoor unit and outdoor unit)
- Install the circuit breaker nearby the units.

### 2 INSTALLING DRAIN PIPE

#### CAUTION

Install the drain pipe in accordance with the instructions in this installation instruction sheet and keep the area warm enough to prevent condensation. Problems with the piping may lead to water leaks.

- NOTE: Install the drain pipe.
- Install the drain pipe with downward gradient (1/50 to 1/100) and so there are no rises or traps in the pipe.
  - Use general hard polyvinyl chloride pipe (VP25) (outside diameter 32 mm) and connect it with adhesive (polyvinyl chloride) so that there is no leakage.
  - When the pipe is long, install supporters.
  - Do not perform air bleeding.
  - Always heat insulate the indoor side of the drain pipe.
  - When desiring a high drain pipe height, raise it up to 800 mm or less from the ceiling within a range of 150 mm from the body. A rise dimension over this range will cause leakage.

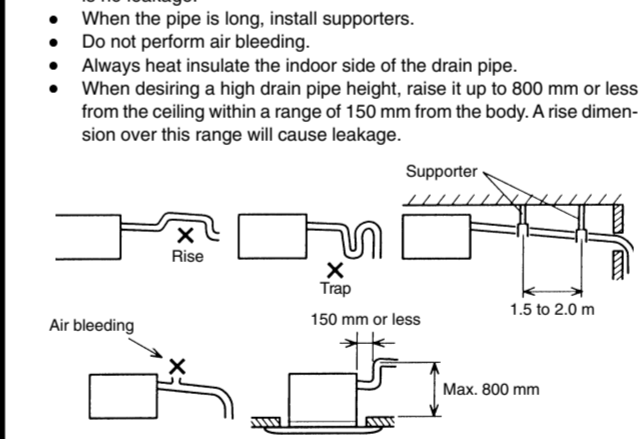

### 3 OUTDOOR UNIT INSTALLATION

#### 1. OUTDOOR UNIT PROCESSING

When the outdoor unit will be exposed to strong wind, fasten it with bolts at the four places indicated by the arrows.

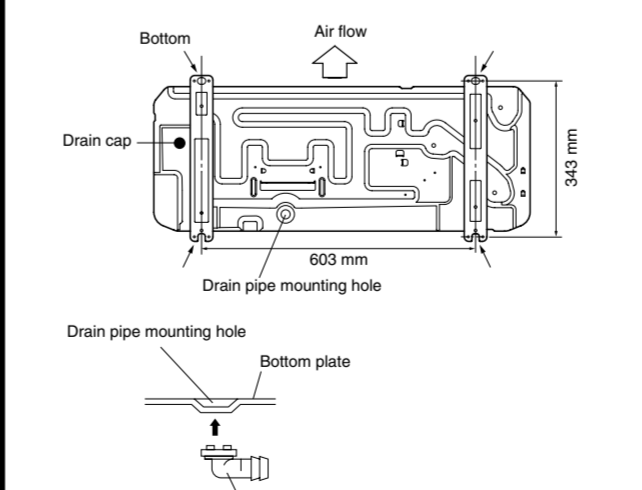

#### CAUTION

If this product is used in an area where the temperature falls below freezing for long periods of time, do not connect the drain pipe. Instead, allow the water to drain into a drain pan.

### 2. OUTDOOR UNIT CONNECTION CABLE AND PIPE CONNECTION PREPARATIONS

- Remove outdoor unit terminal cover.

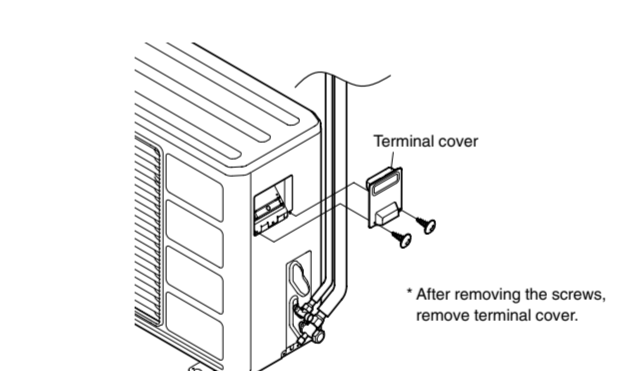

- Connect the piping, connection cable and power supply cable.

### 4 CONNECTING THE PIPING

#### CAUTION

- Do not use mineral oil on flared part. Prevent mineral oil from getting into the system as this would reduce the lifetime of the units.
- While welding the pipes, be sure to blow dry nitrogen gas through them.
- The maximum lengths of this product are shown in the table. If the units are further apart than this, correct operation can not be guaranteed.

#### 1. FLARING

- Cut the connection pipe to the necessary length with a pipe cutter.
- Hold the pipe downward so that cuttings will not enter the pipe and remove the burrs.
- Insert the flare nut (always use the flare nut attached to the indoor and outdoor units respectively) onto the pipe and perform the flare processing with a flare tool. Use the special R410A flare tool, or the conventional flare tool.

Check if [L] is flared uniformly and is not cracked or scratched.

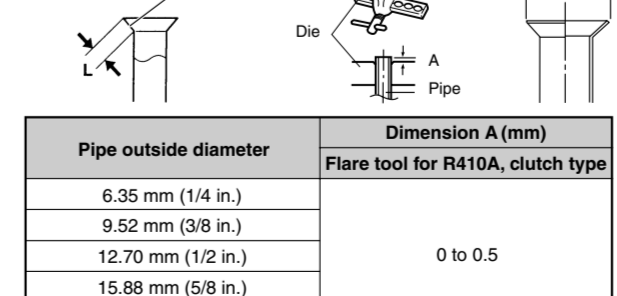

| Pipe outside diameter | Dimension A (mm) |
|-----------------------|------------------|
| 6.35 mm (1/4 in.)     | 0 to 0.5         |
| 9.52 mm (3/8 in.)     |                  |
| 12.70 mm (1/2 in.)    |                  |
| 15.88 mm (5/8 in.)    |                  |
| 19.05 mm (3/4 in.)    |                  |

| Pipe outside diameter | Dimension B (mm) |
|-----------------------|------------------|
| 6.35 mm (1/4 in.)     | 9.1              |
| 9.52 mm (3/8 in.)     | 13.2             |
| 12.70 mm (1/2 in.)    | 16.6             |
| 15.88 mm (5/8 in.)    | 19.7             |
| 19.05 mm (3/4 in.)    | 24.0             |

When using conventional flare tools to flare R410A pipes, the dimension A should be approximately 0.5 mm more than indicated in the table (for flaring with R410A flare tools) to achieve the specified flaring. Use a thickness gauge to measure the dimension A.

| Pipe outside diameter | Width across flats of Flare nut |
|-----------------------|---------------------------------|
| 6.35 mm (1/4 in.)     | 17 mm                           |
| 9.52 mm (3/8 in.)     | 22 mm                           |
| 12.70 mm (1/2 in.)    | 26 mm                           |
| 15.88 mm (5/8 in.)    | 29 mm                           |
| 19.05 mm (3/4 in.)    | 36 mm                           |

### 2. BENDING PIPES

The pipes are shaped by your hands. Be careful not to collapse them. Do not bend the pipes in an angle more than 90°. When pipes are repeatedly bend or stretched, the material will harden, making it difficult to bend or stretch them any more. Do not bend or stretch the pipes more than three times.

#### CAUTION

- To prevent breaking of the pipe, avoid sharp bends. Bend the pipe with a radius of curvature of 150 mm or over.
- If the pipe is bent repeatedly at the same place, it will break.

### 3. CONNECTION PIPES

#### INDOOR UNIT

- Detach the caps and plugs from the pipes.

#### CAUTION

- Be sure to apply the pipe onto the port on the indoor unit correctly. If the centering is improper, the flare nut cannot be tightened smoothly. If the flare nut is forced to turn, the threads will be damaged.
- Do not remove the flare nut from the indoor unit pipe until immediately before connecting the connection pipe.

- Centering the pipe against port on the indoor unit, turn the flare nut with your hand.



To prevent gas leakage, coat the flare surface with silicone grease oil (H48). Do not use mineral oil.

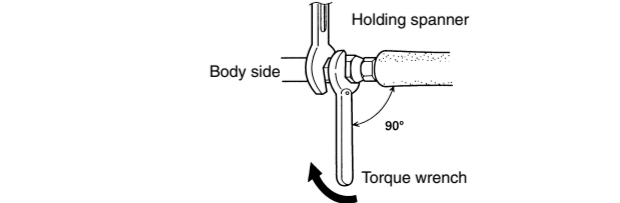
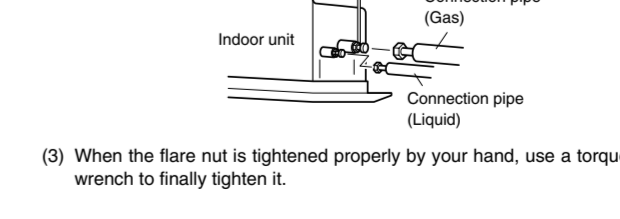

#### CAUTION

Hold the torque wrench at its grip, keeping it in the right angle with the pipe, in order to tighten the flare nut correctly.

| Flare nut               | Tightening torque                  |
|-------------------------|------------------------------------|
| 6.35 mm (1/4 in.) dia.  | 16 to 18 N·m (160 to 180 kgf·cm)   |
| 9.52 mm (3/8 in.) dia.  | 30 to 42 N·m (300 to 420 kgf·cm)   |
| 12.70 mm (1/2 in.) dia. | 49 to 61 N·m (490 to 610 kgf·cm)   |
| 15.88 mm (5/8 in.) dia. | 63 to 75 N·m (630 to 750 kgf·cm)   |
| 19.05 mm (3/4 in.) dia. | 90 to 110 N·m (900 to 1100 kgf·cm) |

</

## 4. CONNECTING THE PIPE

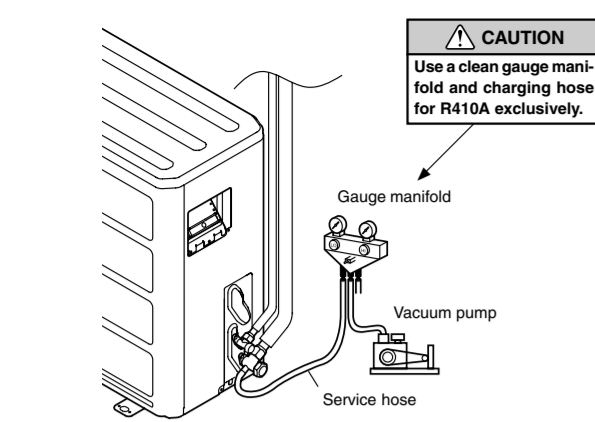

## 5. ADDITIONAL CHARGE

Refrigerant suitable for a piping length of 7.5 m is charged in the outdoor unit at the factory. When the piping is longer than 7.5 m, additional charging is necessary. For the additional amount, see the table below.

| Pipe length   | 7.5 m (25 ft)               | 10 m (33 ft)  | 15 m (49 ft)   | 20 m (66 ft)    | 25 m (82 ft)    |
|---------------|-----------------------------|---------------|----------------|-----------------|-----------------|
|               | Heat & Cool (Reverse cycle) | None          | 100 g (3.5 oz) | 300 g (10.6 oz) | 500 g (17.6 oz) |
| Cooling model | None                        | 50 g (1.8 oz) | 150 g (5.3 oz) | 250 g (8.8 oz)  | 350 g (12.3 oz) |

Between 7.5 m and 25 m, when using a connection pipe other than that in the table, charge additional refrigerant with 40 g (1.4 oz)/1 m (3.3 ft) (Reverse cycle model), 20 g (0.71 oz)/1 m (3.3 ft) (Cooling model) as the criteria.

## CAUTION

- When moving and installing the air conditioner, do not mix gas other than the specified refrigerant (R410A) inside the refrigerant cycle.
- When charging the refrigerant R410A, always use an electronic balance for refrigerant charging (to measure the refrigerant by weight).
- When charging the refrigerant, take into account the slight change in the composition of the gas and liquid phases, and always charge from the liquid phase side whose composition is stable.
- Add refrigerant from the charging valve after the completion of the work.
- The maximum length of piping is 25 m. If the units are further apart than the maximum pipe length, correct operation can not be guaranteed.

## 6. GAS LEAKAGE INSPECTION

### CAUTION

- After connecting the piping, check the all joints for gas leakage with gas leak detector.
- When inspecting gas leakage, always use the vacuum pump for pressure. Do not use nitrogen gas.

## 7. HEAT INSULATION ON THE PIPE JOINTS (INDOOR SIDE ONLY)

After checking for gas leaks, insulate by wrapping insulation around the two parts (gas and liquid) of the indoor unit coupling, using the coupler heat insulation.

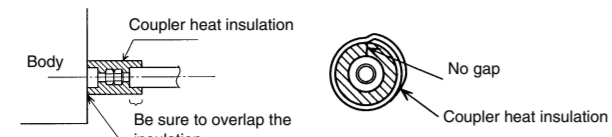

### CAUTION

Must fit tightly against body without any gap.

## 5. ELECTRICAL WIRING

### WARNING

- Before starting work, check that power is not being supplied to the indoor unit and outdoor unit.
- Match the terminal board numbers and connection cable colors with those of the outdoor unit. Erroneous wiring may cause burning of the electric parts.
- Connect the connection cables firmly to the terminal board. Imperfect installation may cause a fire.
- Always fasten the outside covering of the connection cable with the cable clamp. (If the insulator is chafed, electric leakage may occur.)
- Always connect the ground wire.

### HOW TO CONNECT WIRING TO THE TERMINALS

#### A. For solid core wiring (or F-cable)

- Cut the wire end with a wire cutter or wire-cutting pliers, then strip the insulation to about 25 mm to expose the solid wire.
- Using a screwdriver, remove the terminal screw(s) on the terminal board.
- Using pliers, bend the solid wire to form a loop suitable for the terminal screw.
- Shape the loop wire properly, place it on the terminal board and tighten securely with the terminal screw using a screwdriver.

#### B. For strand wiring

- Cut the wire end with a wire cutter or wire-cutting pliers, then strip the insulation to about 10 mm to expose the strand wiring.
- Using a screwdriver, remove the terminal screw(s) on the terminal board.
- Using a round terminal fastener or pliers, securely clamp a round terminal to each stripped wire end.
- Position the round terminal wire, and replace and tighten the terminal screw using a screwdriver.

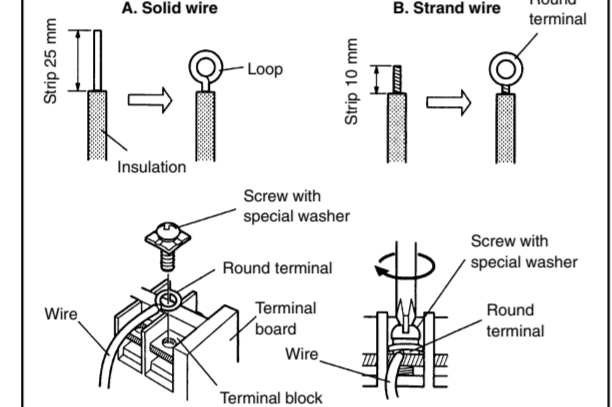

## 8. REMOTE CONTROLLER SETTING

### CAUTION

- When detecting the room temperature using the remote controller, please set up the remote controller according to the following conditions. If the remote controller is not well set, the correct room temperature will not be detected, and thus the abnormal conditions like "not cooled" or "not heated" will occur even if the air conditioner is running normally.
  - A location with an average temperature for the room being air conditioned.
  - Not directly exposed to the outlet air from the air conditioner.
  - Out of direct sunlight.
  - Away from the influence of other heat sources.
- When installing the remote controller and cable near a source of electromagnetic waves, separate the remote controller from the source of the electromagnetic waves and use shielded cable.
- Do not touch the remote controller PC board and PC board parts directly with your hands.

### 1. INSTALLING THE REMOTE CONTROLLER

- Open the operation panel on the front of the remote controller, remove the two screws indicated in the following figure, and then remove the front case of the remote controller.

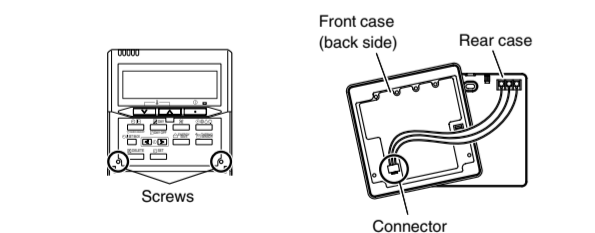

When installing the remote controller, remove the connector from the front case. The wires may break if the connector is not removed and the front case hangs down. When installing the front case, connect the connector to the front case.

- Install the rear case to the wall, etc. with the two tapping screws. Refer to the following information to install the remote controller wires.

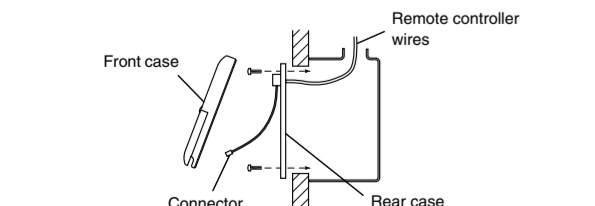

Install the remote controller wires so as not to be direct touched with your hand.

### 2. ROUTING THE REMOTE CONTROLLER WIRES

- Install the remote controller wires to the terminals on the top of the rear case as shown in the following figure.
- Fasten the wires with the binder.

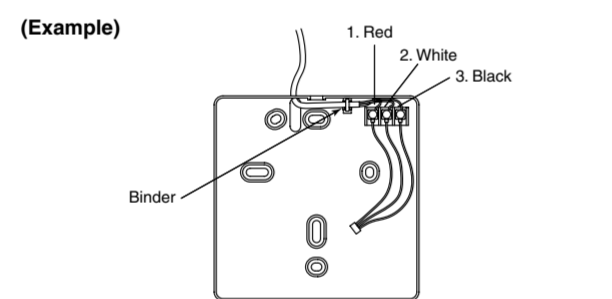

### 3. SETTING THE DIP SWITCHES

When using a battery (memory backup)

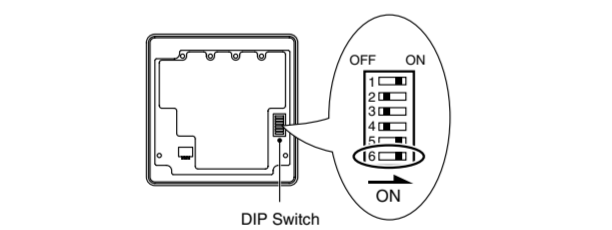

Change the DIP switch setting to use batteries. (The DIP switch is not set to use batteries at the factory.) Change DIP switch No. 6 from OFF to ON. If batteries are not used, all of the settings stored in memory will be deleted if there is a power failure.

### 4. SETTING THE ROOM TEMPERATURE DETECTION LOCATION

The detection location of the room temperature can be selected from the following three examples. Choose the detection location that is best for the installation location.

#### A. Indoor unit setting (factory setting)

The room temperature is detected by the indoor unit temperature sensor.

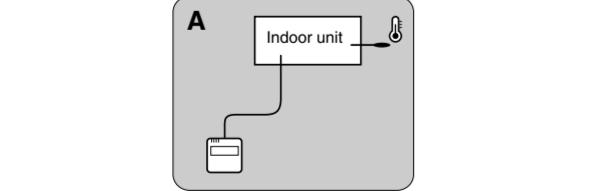

- When the THERMO SENSOR button is pressed, the lock display flashes because the function is locked at the factory.

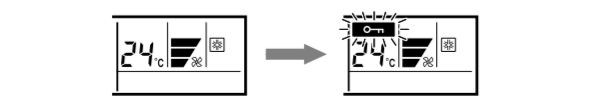

The room temperature is detected by the remote controller temperature sensor.

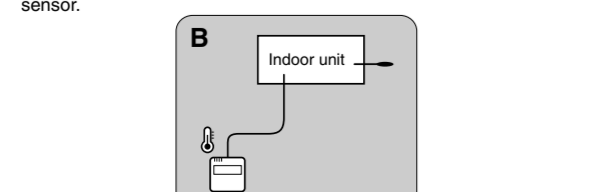

## CAUTION

Do not bundle the remote controller cable, or wire the remote controller cable in parallel, with the indoor unit connection wire (to the outdoor unit) and the power supply cable. It may cause erroneous operation.

### 1. CONNECTION DIAGRAMS

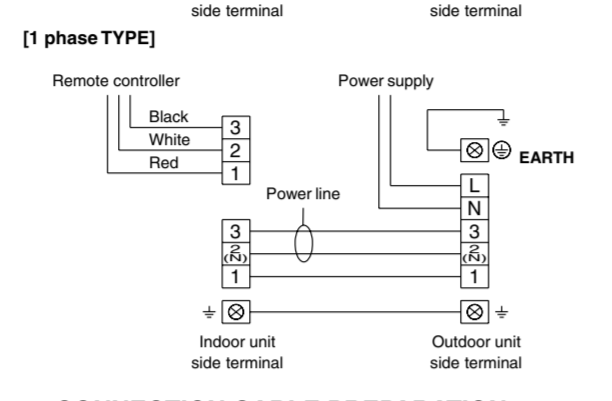
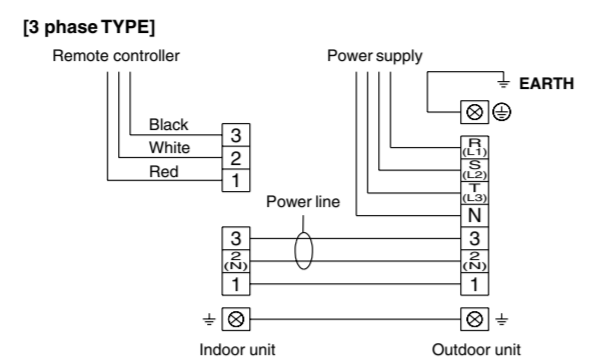

### 2. CONNECTION CABLE PREPARATION

Keep the earth wire longer than the other wires.

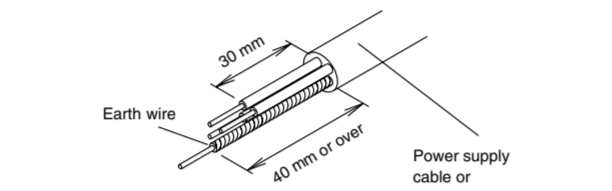

### 3. INDOOR UNIT SIDE

#### CAUTION

Use care not to mistake the power supply cable and connection wires when installing.

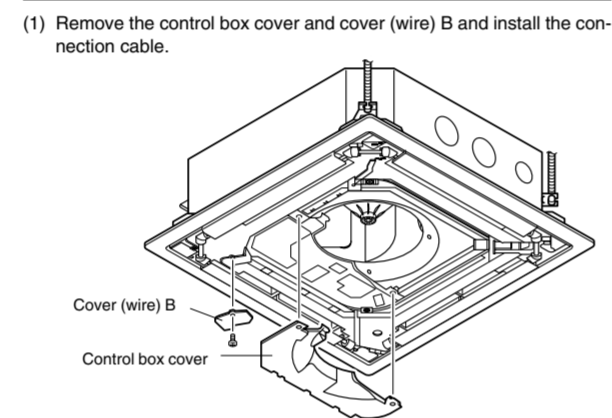

## 2. OUTDOOR UNIT SIDE

- After wiring is complete, clamp the remote controller cable and connection cable with the cable clamp.
- Install the control box cover and cover (wire) B.

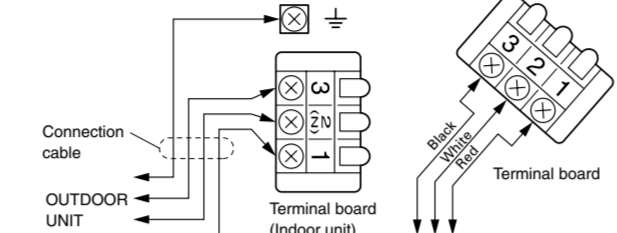
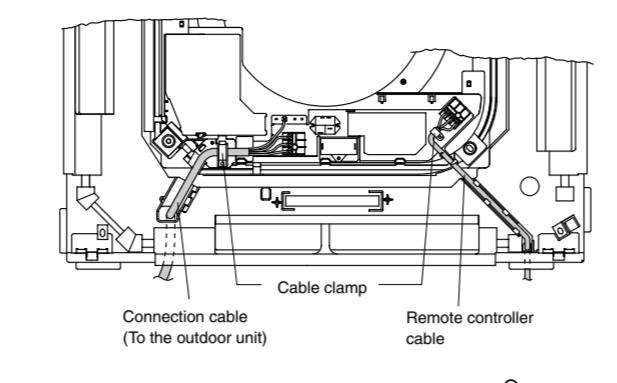

### Ceiling height setting

Set the DIP switch for the ceiling height according to the table below.

| Ceiling height (m) | Normal         | DIP-SW4 |     |
|--------------------|----------------|---------|-----|
|                    |                | 1       | 2   |
| 2.5 - 3.0          | Normal         | OFF     | OFF |
| 3.0 - 3.5          | High ceiling 1 | ON      | OFF |
| More than 3.5      | High ceiling 2 | OFF     | ON  |
| Less than 2.5      | Low ceiling    | ON      | ON  |

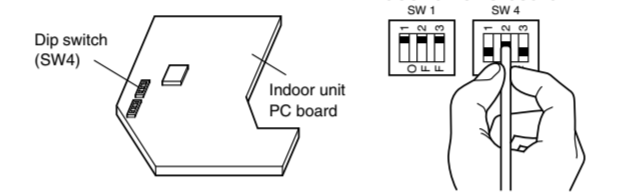

#### CAUTION

- If the setting for a low ceiling is selected, the capacity of the air conditioner decreases slightly.
- Do not set any switches other than those specified in this sheet or the remote controller installation instruction sheet. The air conditioner may not operate correctly if any switches other than those specified are changed.



## 9

## TEST RUN

### CAUTION

Supply power to the crankcase heater for at least 12 hours before the start of operation in winter.

- Stop the air conditioner operation.
- Press the MODE button and the FAN button simultaneously for 2 seconds or more to start the test run.

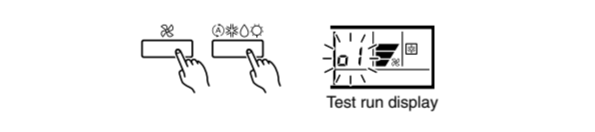

### [SELF-DIAGNOSIS]

When the error indication "E:EE" is displayed, follow the following items to perform the self-diagnosis. "E:EE" indicates an error has occurred.

#### 1. REMOTE CONTROLLER DISPLAY

- Stop the air conditioner operation.
- Press the SET TEMP. buttons A / V simultaneously for 5 seconds or more to start the self-diagnosis. Refer to the following tables for the description of each error code.

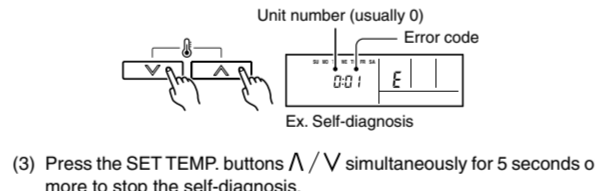

#### 2. INDOOR UNIT DISPLAY

| Error code | Error contents  |
|------------|---|
| 00         | Communication error (indoor unit → remote controller)     |
| 01         | Communication error (indoor unit → outdoor unit)          |
| 02         | Room temperature sensor open                              |
| 03         | Room temperature sensor short-circuited                   |
| 04         | Indoor heat exchanger temperature sensor open             |
| 05         | Indoor heat exchanger temperature sensor short-circuited  |
| 06         | Outdoor heat exchanger temperature sensor open            |
| 07         | Outdoor heat exchanger temperature sensor short-circuited |
| 08         | Power source connection error                             |
| 09         | Float switch operated                                     |
| 0A         | Outdoor temperature sensor open                           |
| 0b         | Outdoor temperature sensor short-circuited                |
| 0C         | Discharge pipe temperature sensor open                    |
| 0d         | Discharge pipe temperature sensor short-circuited         |
| 0E         | Outdoor high pressure error                               |
| 0F         | Discharge pipe temperature error                          |

When the fault is cleared, the LED lamp goes off. However, for discharge pipe temperature abnormal and high pressure abnormal, the LED lamp lights continuously for 24 hours, as long as the power is not turned off.

#### 3. CHECKING DRAINAGE

To check the drain, remove the water cover and fill with 2 to 3 l of water as shown in the figure. The drain pump operates when operating in the cooling mode.

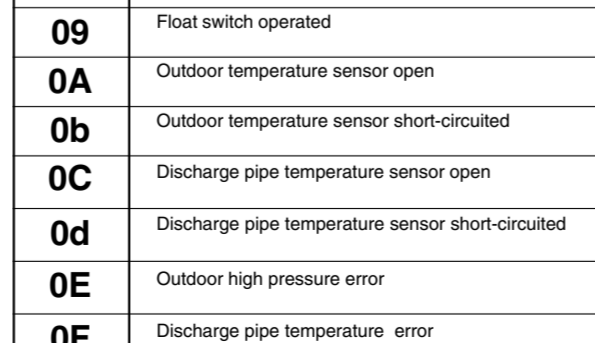

### NOTES

If the function to change the temperature sensor is used as shown in examples A and B (other than example C), be sure to lock the detection location. If the function is locked, the lock display will flash when the THERMO SENSOR button is pressed.

## 4. OUTDOOR UNIT SIDE

### CAUTION

When connecting the power supply cable, make sure that the phase of the power supply matches with the phase of the terminal board. If the phases do not match, the compressor will rotate in reverse and will not be able to compress.

- Remove the terminal cover of the outdoor unit, and insert the end of the connection cable and the power supply cable into the terminal board.
- Fasten the connection cable and the power supply cable with the cable clamp, and install the terminal cover.

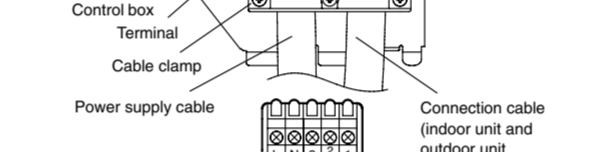
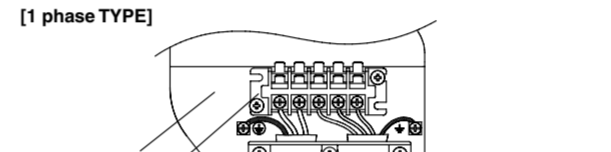
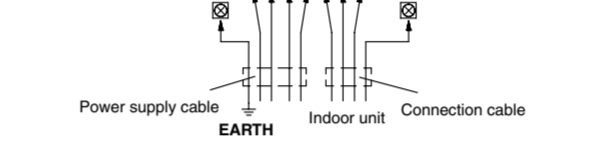
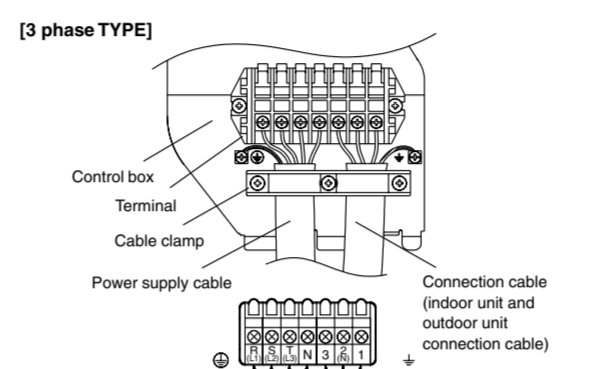
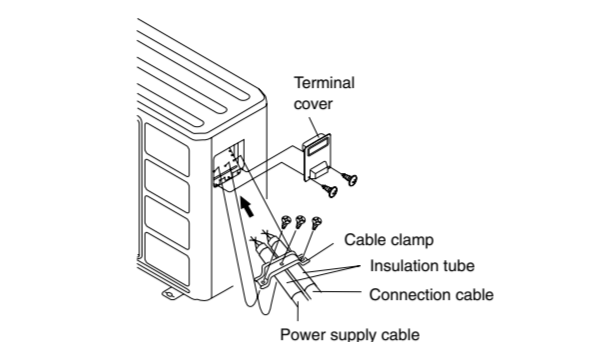

#### CAUTION

When routing the ground wires, leave slack as shown in the illustrations.

## 6

## GRILLE INSTALLATION

### BLOWER COVER INSULATION

Install the blower cover insulation only when the outlet direction is not specified. Two blower cover insulations are packed with the indoor unit. Install the blower cover insulation at the diffuser position shown in the figure. At this time, use the piping position as the criteria.

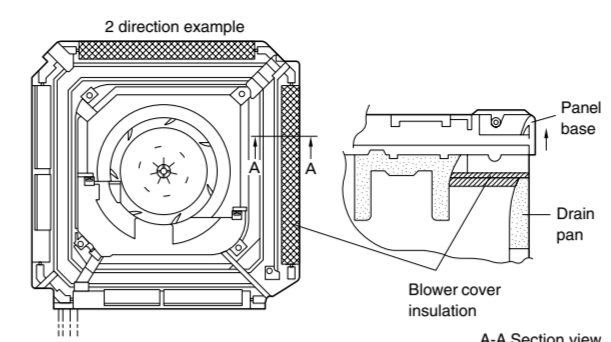

### INSTALLING THE INTAKE GRILLE

- Mount the grille hinge wire to the hook shaft as shown in the figure.

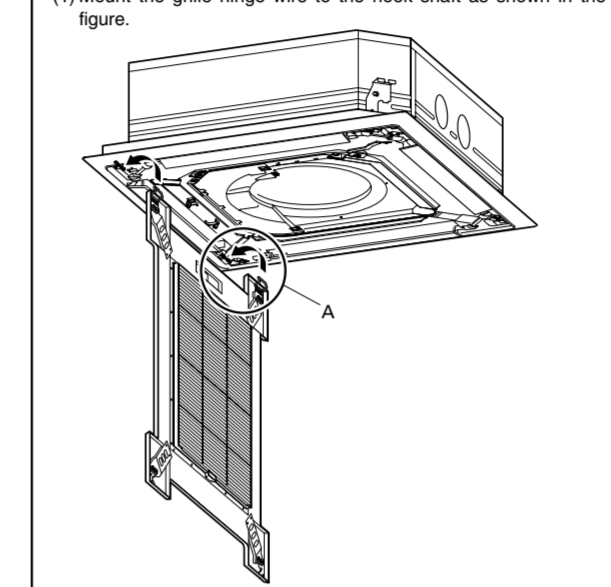

- Latch the grille hinge wire to the hook shaft, and fasten.

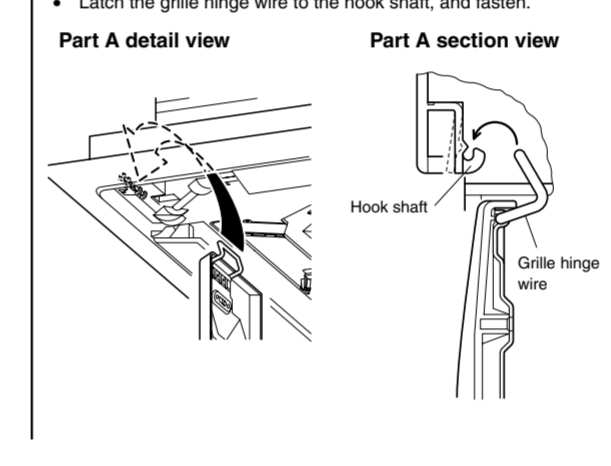

#### CAUTION

When routing the ground wires, leave slack as shown in the illustrations.

## 7

## POWER

### WARNING

- 3 phase TYPE
  - The rated voltage of this product is 400 V 3N - 50 Hz. Before turning on, verify that the voltage is within the 342 V to 457 V range.
- 1 phase TYPE
  - The rated voltage of this product is 230 V - 50 Hz. Before turning on, verify that the voltage is within the 198 V to 264 V range.

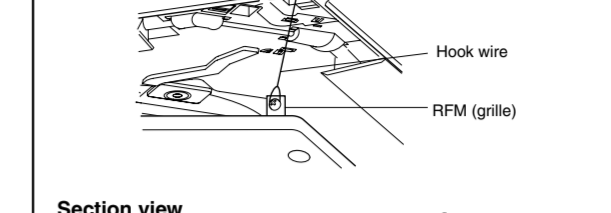

### Section view

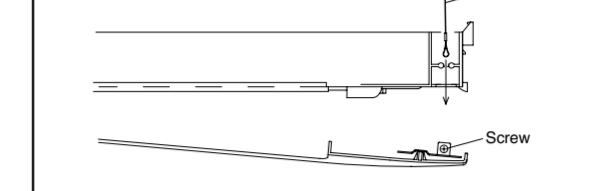

### Section view

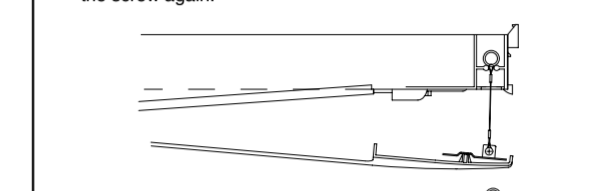

### Section view

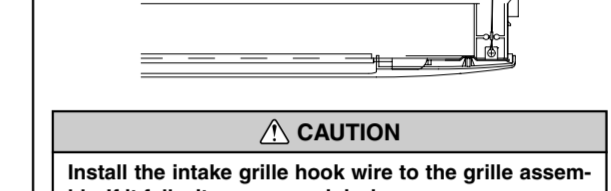

### Section view



### Section view

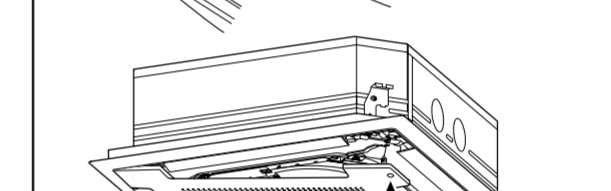

### Section view

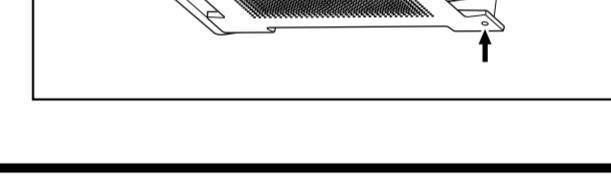

### Section view

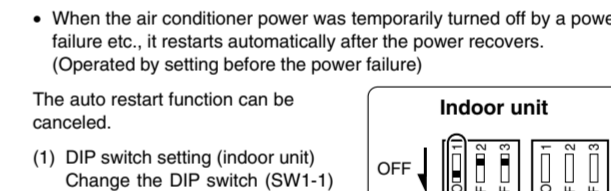

### Section view

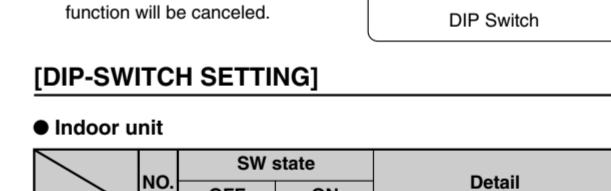

### Section view

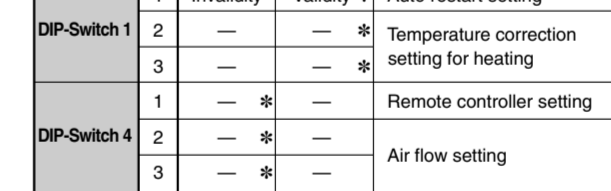

### Section view

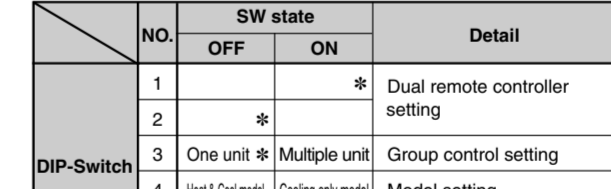

### Section view

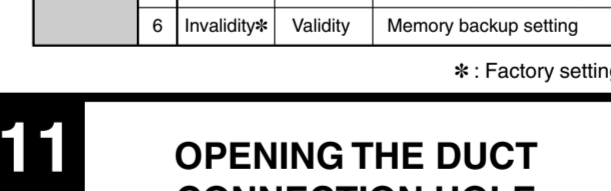

### Section view

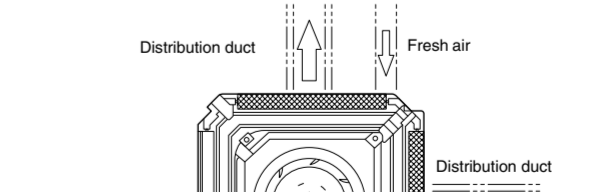

### Section view



### Section view

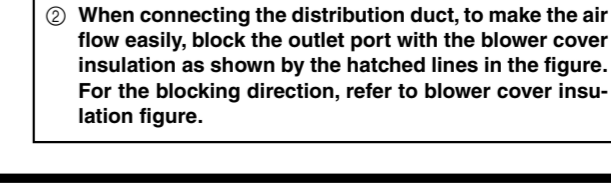

### WARNING

- 3 phase TYPE
  - The rated voltage of this product is 400 V 3N - 50 Hz. Before turning on, verify that the voltage is within the 342 V to 457 V range.
- 1 phase TYPE
  - The rated voltage of this product is 230 V - 50 Hz. Before turning on, verify that the voltage is within the 198 V to 264 V range.
- Always use a special branch circuit and install a special receptacle to supply power to the air conditioner.
- Use a special branch circuit breaker and receptacle matched to the capacity of the air conditioner. (Install in accordance with standard.)
- Perform wiring work in accordance with standards so that the air conditioner can be operated safely and positively.
- Install a leakage special branch circuit breaker in accordance with the related laws and regulations and electric company standards.

### CAUTION

- The power source capacity must be the sum of the air conditioner current and the current of other electrical appliances. When the current contracted capacity is insufficient, change the contracted capacity.
- When the voltage is low and the air conditioner is difficult to start, contact the power company the voltage raised.
- This air conditioner must be connected to a power source that has an electrical impedance of 0.159 Ω or less or has a supply current of 100 A or greater. If the power supply does not meet the specifications, contact the power company.

### CAUTION

Install the intake grille hook wire to the grille assembly. If it falls, it may cause injuries.

- Bring up the intake grille by pushing it up at an angle as shown in the figure, and fasten.



### Section view

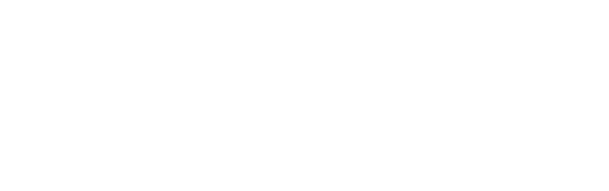

### Section view

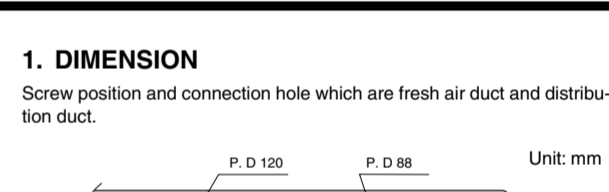

### Section view

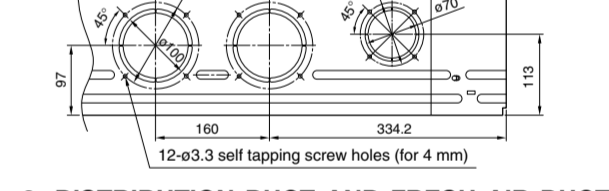

### Section view

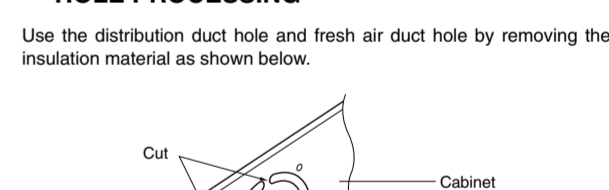

### Section view

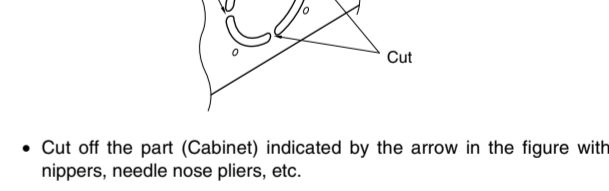

### Section view

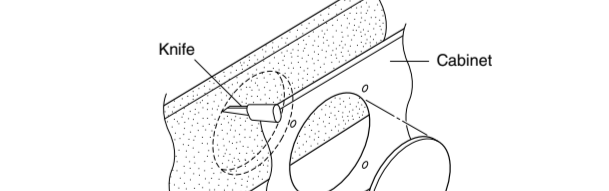

### Section view

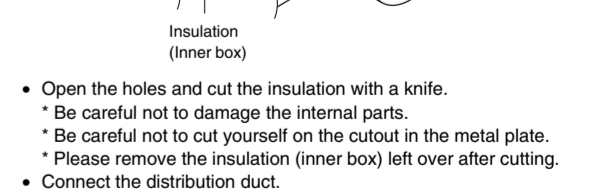

### Section view

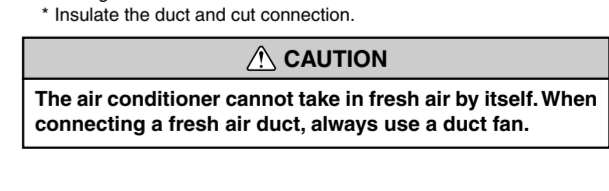

### Section view



### Section view

